

# OT5008

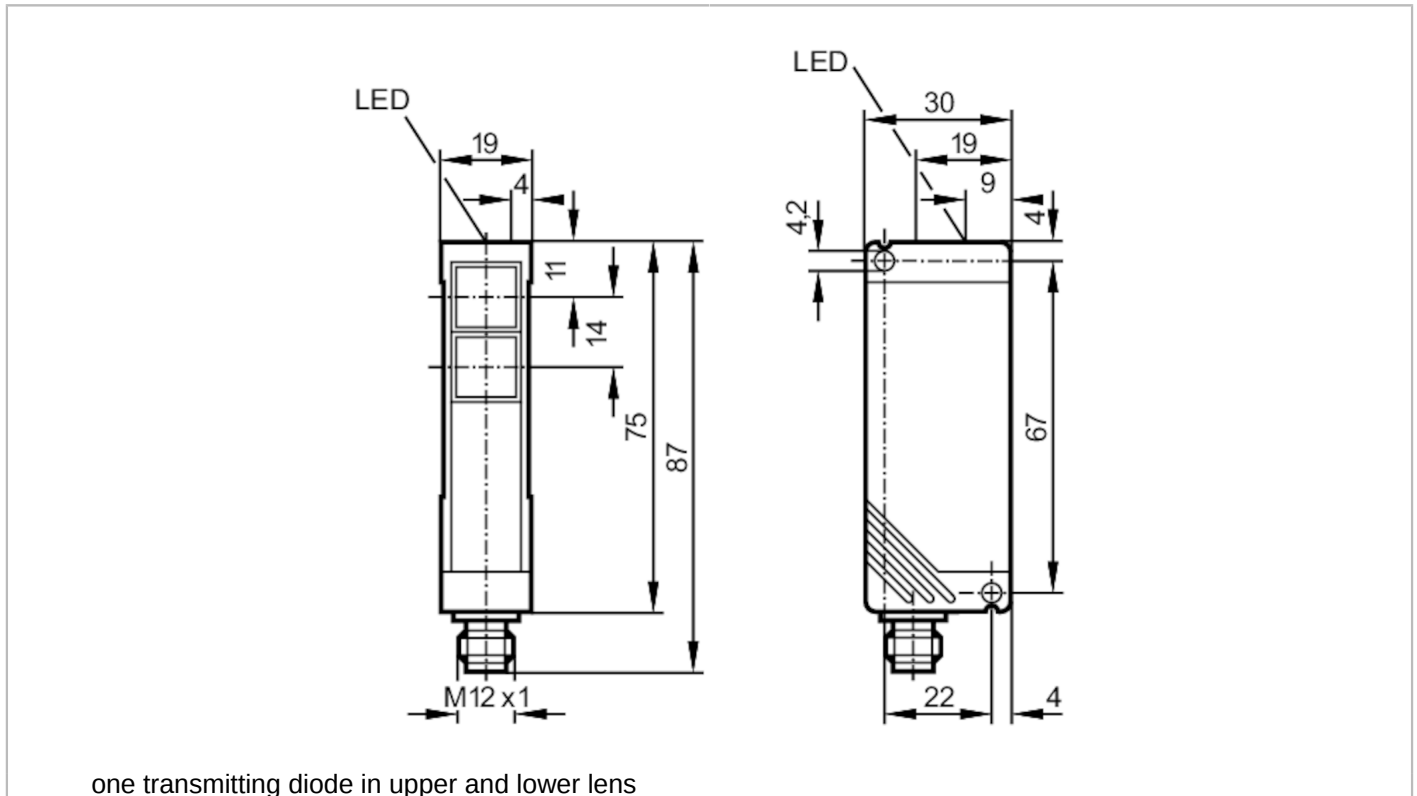

## Through-beam sensor transmitter

OTS-00KG/US-100



Product characteristics		
Type of light		Infrared light
Housing		rectangular
Application		
Function principle		Through-beam sensor
Electrical data		
Operating voltage	[V]	10...50 DC
Current consumption	[mA]	20; ((24 V))
Protection class		II
Reverse polarity protection		yes
Type of light		Infrared light
Wave length	[nm]	880
Monitoring range		
Transmitter / receiver		transmitter
Range	[m]	< 10
Range adjustable		no
Max. light spot diameter	[mm]	524
Light spot dimensions refer to		at maximum range
Operating conditions		
Ambient temperature	[°C]	-25...60
Protection		IP 65

# OT5008



## Through-beam sensor transmitter

OTS-00KG/US-100

### Tests / approvals

EMC	EN 60947-5-2	
	EN 55011	class B
MTTF [years]		1862

### Mechanical data

Weight [g]	153
Housing	rectangular
Material	PBT
Lens material	PMMA
Lens alignment	Side sensing

### Displays / operating elements

Display	Power	1 x LED, green
---------	-------	----------------

### Accessories

Items supplied	Angle bracket: 1, E20461
	screwdrivers

### Remarks

Pack quantity	1 pcs.
---------------	--------

### Electrical connection

Connector: 1 x M12

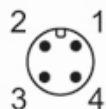

### Connection

